



All-In-One Bulk System

STREAMLINED BYOC WEIGH LABELLING SOLUTION
FOR BULK PRODUCT RETAIL



WEIGHING SCALES

www.wedderburn.com.au

DIGI's All-In-One Bulk System offers a no-fuss, tare-free and streamlined solution for zero-waste bulk product retailing.

DIGI's tare-free streamlined solution for bulk product retailing accelerates efficiency, customer engagement and packaging-free choices available.

With real-time trade-approved weighing, and options of Hopper, Scoop or Liquid Scales, customers can use their own reusable containers across a greater range of bulk product from pantry staples to spices, herbs and even vinegars.



With the All-In-One Bulk System, weight and pricing of the dispensed product is automatically displayed on the console's screen ready for label printing. Eliminating the need for an operator to select a PLU helps reduce errors and simplifies the shopping process.

The innovative system also eliminates the need for containers to be tared as product is weighed prior to being dispensed into the customer's container.

Streamlined Operation

- ✓ Auto PLU Callup - no need to search for PLUs
- ✓ No container tare required
- ✓ Multiple shoppers can operate at the same time



Flexible Configuration

Each setup consists of a single SM-6000 Printer Console that can be linked to multiple Hopper, Scoop and Liquid Scales, allowing retailers to mix and match different types of dispensers while offering a wider selection of packaging-free products for bulk retailing.

Dispense • Scoop • Pour

This sustainable solution incorporates 3 types of scales to accommodate a wider range of product and container-filling methods, and can be added to over time.



Specifications may change without notice

All-In-One Bulk System

Sustainable Operations

Apart from making plastic-free bulk shopping a reality, this system combines linerless labelling with low power consumption to help retailers reduce waste and carbon emissions while establishing climate-friendly operations.

Zero Waste

- ✓ Packaging-free shopping
- ✓ Linerless labelling
- ✓ Low power consumption
- ✓ Customers can buy the quantity they need



Electronic Product Labels

DIGI's Info Tag is an enterprise-grade electronic shelf label that grants pricing automation via wireless updates. They can be easily incorporated on the Hopper, Scoop and Liquid Scales to display product or promotional information with timely and accurate price updates.

Electronic Info Tags

Accurate, versatile and durable, DIGI's electronic shelf labels set exceptional standards in customer experience and store efficiency with accurate and timely price updates and shopper engagement.



SYSTEM SUMMARY

- streamlined tare-free solution for bulk product retailing
- NMI approved Hopper, Scoop and Pour Scales available
- SM-6000 Printer Console with linerless labelling
- packaging-free shopping
- smart design eliminates PLU search requirement
- no taring of container weight needed
- multiple shoppers can operate simultaneously
- item's weight and price shown in real time
- customers can purchase the quantity they need reducing waste
- hygienic product handling



Specifications may change without notice

All-In-One Bulk System

SPECIFICATIONS

MODEL	HOPPER SCALE	SCOOP SCALE	LIQUID SCALE	SM6000 PRINTER CONSOLE
				
Scale Capacity	1.5 kg x 1 g	30 kg x 5 g	30 kg x 5 g	-
Label Receipt	-	-	-	Linerless with Auto-Cutter Max 95 mm Max 62 mm Max 61 mm Max 150 mm / second*1 300 dpi
Display	3 x 7 Segments LCD (6 digits)	4 x 7 Segments LCD (5 digits and 6 digits x 2 each)		15" TFT XGA with Capacitive Touch Screen (768 x 1024)
Keyboard	1 x Confirm Button			-
Power Source	DC 7V (Max 100 mA)			AC - DC Power Adaptor
Interface (with DC Power)	RS485 (RJ45 Connector)			
Maximum Connection	Support up to 100 units of Hopper, Scoop or Liquid Scales per SM-6000 Printer Console			
Operating Temperature	- 10 °C to + 40 °C			
Humidity	15% to 85% RH Non-Condensation			
Dimensions W x H x D (mm)	100 x 347 x 214	210 x 357 x 54	210 x 365 x 271	280 x 206 x 576
Net Weight	1.4 kg	3.3 kg	3.7 kg	8 kg
Options				<ul style="list-style-type: none"> Wireless LAN IEEE 802.11 a/b/g/n/ac InfoTag Base Station

*1 To achieve maximum print speed, high sensitivity thermal paper is necessary.

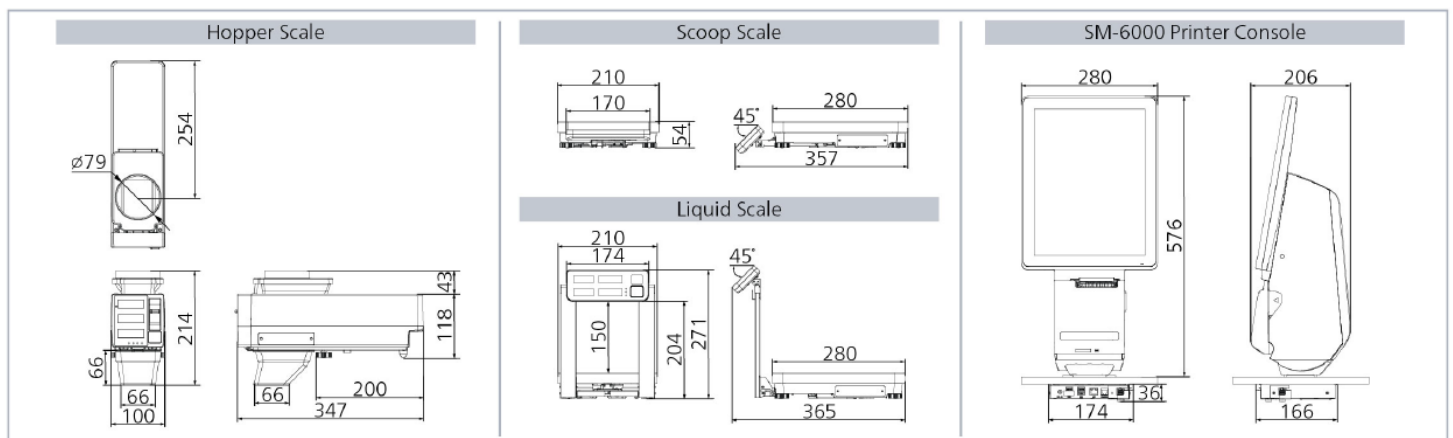

WEIGHING EQUIPMENT

LABELS | LABELLING EQUIPMENT | PACKAGING EQUIPMENT
ESL & DIGITAL SIGNAGE | WEIGHING SCALES | POS SYSTEMS
FOOD EQUIPMENT | MAINTENANCE & REPAIRS | HIRE

Specifications may change without notice

1300 970 111
enquiries@wedderburn.com.au
www.wedderburn.com.au