

Continuous Band Sealer

Model : WFCBSV14

Our stainless steel vertical continuous band sealing machines speed up production and make light work out of sealing plastic bags and film. These reliable machines are engineered for many industries including; food, medical, cosmetics and componentry.

FEATURES

- suitable for sealing small packages
- durable stainless steel construction
- easy to use as the operator only needs to feed the bags or material into the machine
- temperature controller ensures consistent temperature throughout the operation for quality sealing
- temperature can be adjusted to suit the job at hand
- conveyor belt speed regulation
- sealing direction is left to right
- distance between the between conveyor and sealer can be adjusted to suit the item currently being sealed

OPTIONS

- horizontal model available upon request (WFCBSH14)



Specifications may change without notice

PACKAGING EQUIPMENT

Continuous Band Sealer

Model: WFCBSV14

SPECIFICATIONS

Machine dimensions (mm):	840 (W) x 380 (L) x 550 (H)
Sealing width (mm):	8
Distance from sealer to conveyor (mm):	200 - 320
Temperature range (°C):	0 - 300
Conveyor size (mm):	840 (W) x 153 (D)
Max. conveyor loading	
Single package:	1 kg
Total load:	3 kg
Voltage:	AC 220/50 Hz
Net weight:	37 kg

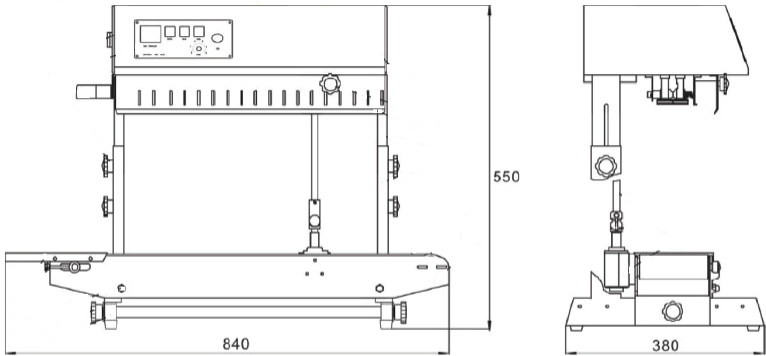

PACKAGING EQUIPMENT

LABELS | LABELLING EQUIPMENT | PACKAGING EQUIPMENT
ESL & DIGITAL SIGNAGE | WEIGHING SCALES | POS SYSTEMS
FOOD EQUIPMENT | MAINTENANCE & REPAIRS | HIRE

Specifications may change without notice

1300 970 111
enquiries@wedderburn.com.au
www.wedderburn.com.au